

⑥ RUNNERS, partly from DN-class

Ice Optimist youth-iceboat

INSERT RUNNER

Steel, thickness 3 - 6.8 mm, height 50 - 76 mm

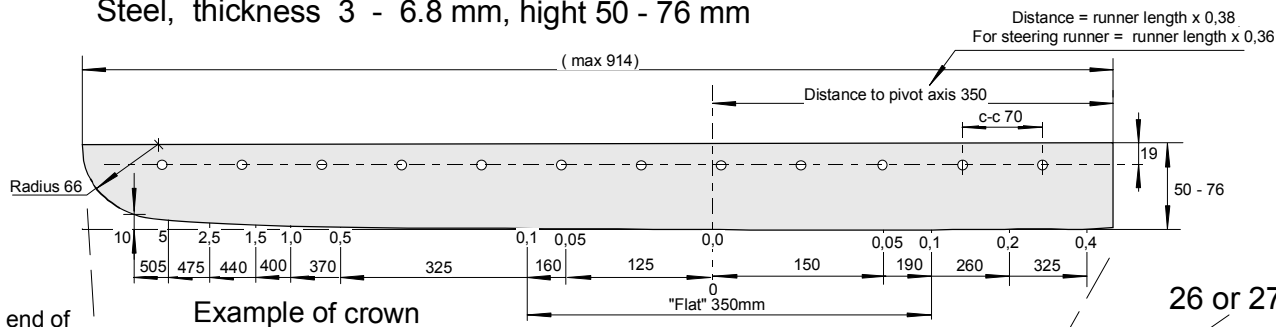

Front end of runner smooth rounded not less than radius 15 mm.

Front edge above ice rounded not sharp.

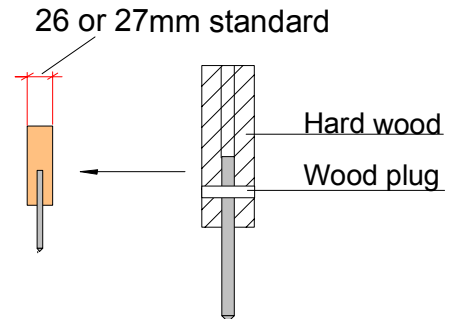
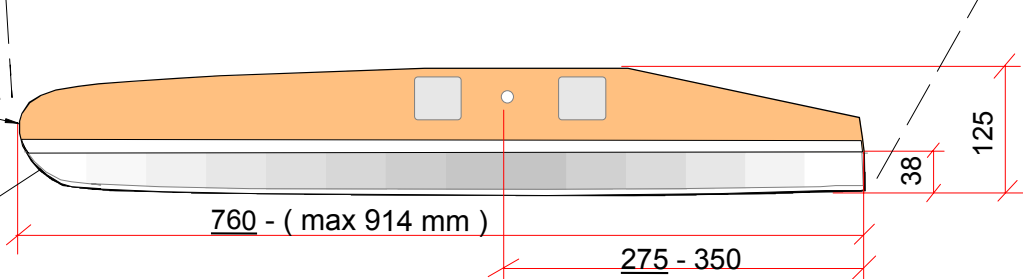

Both of this specs. are designed to prevent, sharp leading edges on runners, witch might cut a sailor in a collision.

PLATE RUNNER

Steel, thickness 3 - 6.8 mm, height 95 - 127 mm

Front end of runner smooth rounded not less than radius 15 mm.

Front edge above ice rounded not sharp.

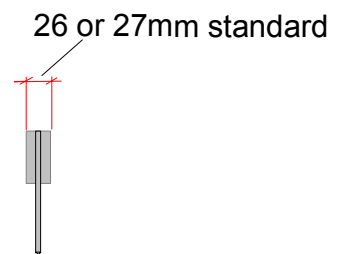
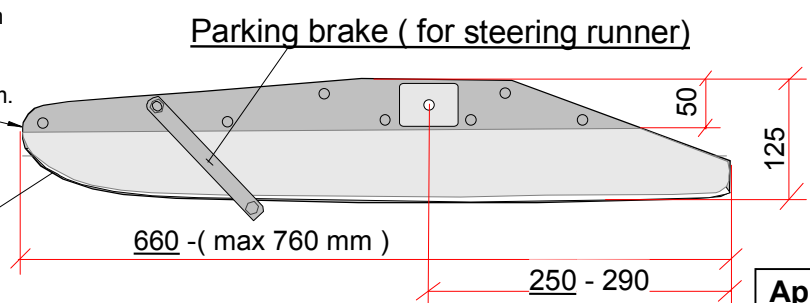

Ice Optimist,
youth iceboat.
Drawn by: J. Adsten
Date: 2002-05-21
Doc: iceoptim.ds4



Approved by IDNIYRA Europe 2002-04-21